

# WehoManholes

*Lightweight High Density Polyethylene Manholes*

WehoManholes



## WehoManholes *Lightweight High Density Polyethylene Manholes*

KWH Pipe is the manufacturer of WehoManholes, a lightweight high density polyethylene manhole system. WehoManholes are available in sizes ranging from 36" (910mm) to 120" (3050mm) ID. Our product is flexible and extensive, enabling engineers to meet requirements of the most demanding projects. All manholes manufactured by KWH Pipe conform to ASTM F1759 and are accompanied by shop drawings. All WehoManholes are quality assurance inspected and air tested before shipment.



KWH Pipe ensures the stakeholder will receive professional sales and engineering support from our personnel during the design phase as well as after sales support. KWH Pipe also offers manhole design assistance to help stakeholders create a custom solution catered toward their requirements.



### WehoManholes are ideal for:

- Leachate extraction chambers/leachate collection wells
- Decant structures
- Groundwater control shafts
- Leak detection manholes
- Inspection chambers and industrial/municipal manhole applications
- Wet Wells

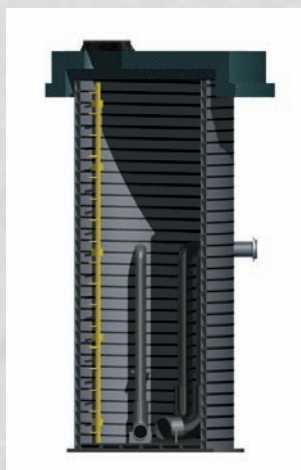

3D Concept of H2O Loading Cap



H2O Loading Cap

## WehoManhole Applications:

- Landfills
- Mining
- Industrial
- Sanitary Sewers
- Hydroelectric
- Municipal
- Storm drains
- WehoTank inspection chambers



## Advantages of WehoManholes vs Traditional Manholes

- Long service life
- Corrosion Resistant
- Superior abrasion resistance
- Immune to normal loads of hydrogen sulfide and sulphuric acid
- Leak proof structures
- Prefabricated benching for faster installations
- Lightweight for easier installation and reduced project costs
- Economical with short lead times
- Professional sales and engineering support
- Suitable for burial depths up to 50'
- Custom fabricated manholes are available



## Manhole Custom Options:

- Multiple inlet configurations
- Channeling
- Flat bottom
- Benched bottom
- FRP ladders
- FRP/Aluminum landing platforms
- Hinged lid
- Lockable lid

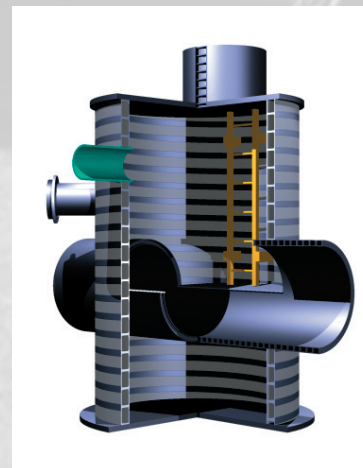

# Weholite

*Versatile lightweight pipe system for gravity and low-pressure applications*



The accuracy or applicability of all information contained herein is intended as a guide and is not guaranteed. Hence, KWH Pipe assumes no obligation or liability for this information. All tables and statements may be considered as recommendations but not as warranty. Users of our products should perform their own tests to determine the suitability of each such product for their particular purposes. KWH Pipe's liability for defective products is limited to the replacement, without charge, of any product found to be defective. Under no circumstances shall it be responsible for any damages beyond the price of the products, and in no event shall it be liable for consequential damages.



Registered to  
ISO 9001

**KWH Pipe**  
6507 Mississauga Road, Mississauga  
Ontario, Canada L5N 1A6  
Tel.: 905-858-0206 • Fax: 905-858-0208  
Toll Free: 1-866-KWH-PIPE (594-7473)  
sales@kwhpipe.ca • [www.kwhpipe.ca](http://www.kwhpipe.ca)  
[www.weholite.com](http://www.weholite.com)

